

WHAT IS THE DIFFERENCE BETWEEN A VECTORIZED EPS FILE AND A REGULAR EPS FILE?



This is a JPEG file CONVERTED to EPS



This is a vectorized EPS file

If you take a JPEG file or a multi-color TIFF file and convert it to a EPS file it DOES NOT vectorize the artwork. It just changes the file format and it is now a EPS file that RETAINS all the unusable qualities of the original JPEG or multi-color TIFF file.

A vectorized file is created with a computer program such as Adobe Illustrator or Macromedia Freehand, or Canvas to name a few. These are vector based art programs.

The vectorized eps file is the best format for the customer, in that it speeds up production time.

If we have to recreate a JPEG file, depending on the complexity of the artwork, it can take anywhere between 5 and 8 hours, that will be billable by the hour as extra art time charges.

By being vectorized we can do color separations much easier and quicker ensuring that your final product will look as clean and sharp as possible.

THESE ARE THE BEST FILES TO SUBMIT TO THE ART DEPARTMENT

ELECTRONIC ART

- Illustrator vectorized EPS files
- 1 color High Resolution TIFF file (300 dpi)

We are Macintosh based, when submitting art please include any fonts (typefaces) that you may have used or convert the fonts into outlines (art).

Art can be sent to us electronically via e-mail, or put on a CD, Zip Disk or a Floppy Disk. Please do not compress or stuff the files as we have found that many times the files become corrupt and we cannot open them. Please include in any Pantone (PMS) numbers that were used in the art.

THE DIFFERENCES BETWEEN A JPEG FILE AND A VECTORIZED EPS FILE



This is a JPEG file

This is a vectorized EPS file

At first glance both files look the same, even though they both get their point across there are many differences. A JPEG file is usually a low resolution image which is mostly used in web pages. It cannot be manipulated to meet our printing needs. On the other hand a vectorized EPS file can be manipulated in any shape or form to turn out higher quality for your decorated glassware. See the examples below.

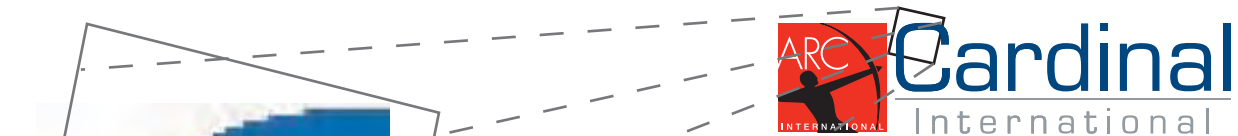

JPEG file

Increased portion of logo

Example: If we were to increase the size of the JPEG you can see the BITMAPPING (JAGGED LINES) that occurs, the more you increase the JPEG the worse it looks and the resolution deteriorates the bigger you go.



EPS file

Example: If we were to increase the size of the EPS there is NO BITMAPPING, the logo remains as crisp as it was in it's original size. In theory you can take a Vectorized EPS file that is about an inch in size and resize it as large as a billboard and lose no detail or integrity of the file.

Increased portion of logo

Fonts

When supplying us with art please include the font files used or convert the fonts into outlines (or Curves). If we do not have the correct font files the computer will try to compensate for the missing font with one that it deems suitable, more times than not it will choose a font that does not resemble yours, the spacing and placement of the letters may also become distorted as the examples below show.



Original Art
with correct
font

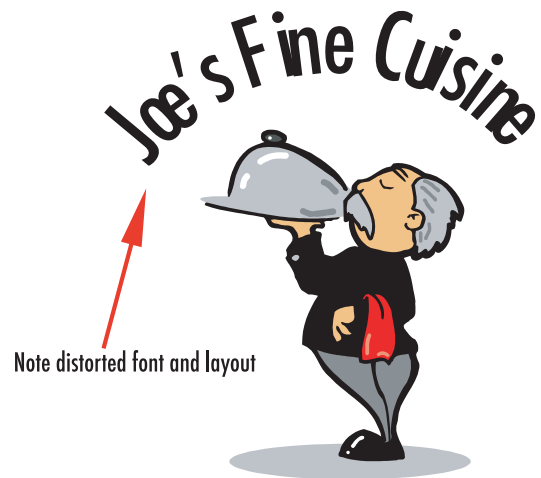

Original Art
without correct
font

The fancier the font, for example, if it contains fine serifs or swirls, the more of a chance that it might not print well, especially if it is printing in a very small area.

Example

CARDINAL

This text would be difficult to reproduce at this size

Due to FDA regulations,
we cannot print
above 1" from the lip of
the glass

Glass specifications for
item 3032237 16 oz. Mixing Glass

We are Macintosh based
and accept artwork in the
following formats:
Vectorized EPS files or 1
color TIFF files. Or 1 color
Camera ready art(Slick or Velox).
Please include all fonts with the
art file or convert them into
outlines. Please include all
PMS numbers for your colors.

Our glasses are screen printed
using spot colors. We can currently
print anywhere between 1 and 8
colors.

The print area is as follows:

As far as the height is
concerned the max we
can print is 3 3/4 " in height.

As far as width is concerned
we can print a full wrap around
the glass, the maximum width
being 9.09 ",leaving a 1/4 " gap
between the art.

3.75"

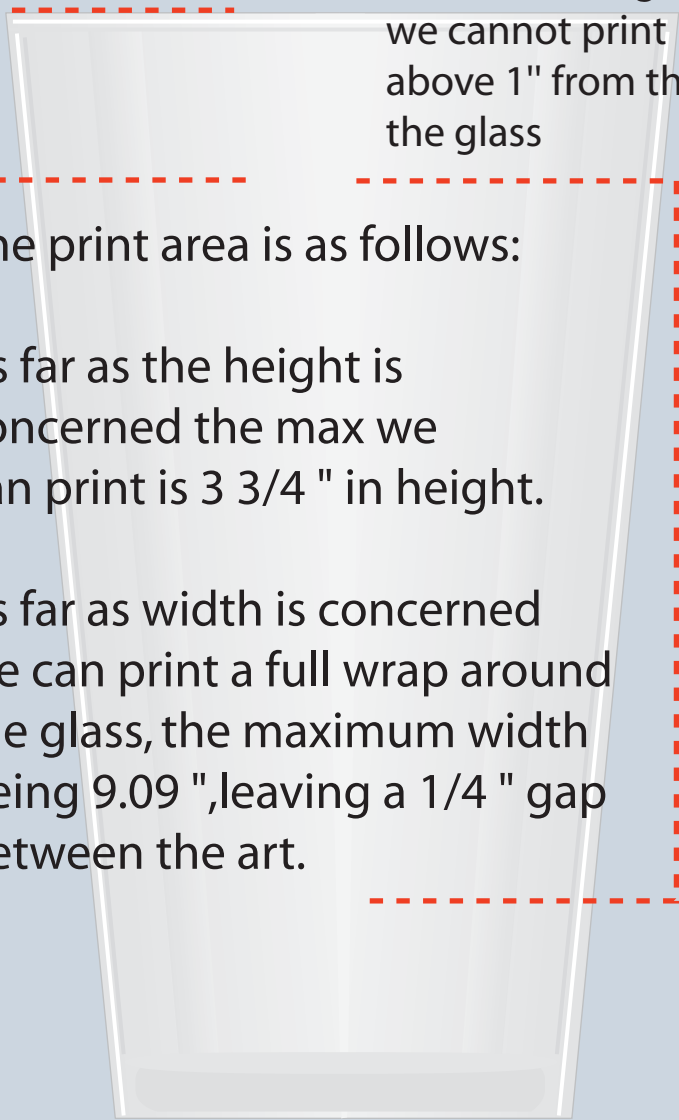

3032237
16 oz. Mixer

EXAMPLE



When a Full Wrap
is printed the art does
not "touch" or "meet",
instead there is a 1/4"
gap in between the art.

EXAMPLE



If your logo is NOT a full wrap, but is 1 or 2 sided,
In order for your logo to remain legible
it should not exceed 3.3" in width.

EXAMPLE



Please keep in mind that if you are
printing a square logo, or printing
close to the bottom of the glass
tapering will take place due to the
taper in the glass.

PMS Colors

PMS 1767	PMS 1777	PMS 1787	Red 032	PMS 1797	PMS 1807	PMS 1817
PMS 182	PMS 183	PMS 184	PMS 185	PMS 186	PMS 187	PMS 188
PMS 189	PMS 190	PMS 191	PMS 192	PMS 193	PMS 194	PMS 195
PMS 1895	PMS 1905	PMS 1915	PMS 1925	PMS 1935	PMS 1945	PMS 1955
PMS 196	PMS 197	PMS 198	PMS 199	PMS 200	PMS 201	PMS 202
PMS 203	PMS 204	PMS 205	PMS 206	PMS 207	PMS 208	PMS 209
PMS 210	PMS 211	PMS 212	PMS 213	PMS 214	PMS 215	PMS 216
PMS 217	PMS 218	PMS 219	Rubine Red	PMS 220	PMS 221	PMS 222
PMS 223	PMS 224	PMS 225	PMS 226	PMS 227	PMS 228	PMS 229

When choosing what colors to print please try to provide us with a PMS (Pantone Matching System) number. Sometimes a customer will tell us to “just print RED”. If you look at the chart you will notice that there are many different “REDS” you can choose from and this is only a small sampling.

The chart is an example of a page from a PMS book. In a PMS book all colors are assigned a number. You can purchase a PMS book from any art supply store or visit the following web page <http://www.pantone.com> for more information.

Keep in mind that if you visit the web page the colors you see on your screen will vary from what is actually printed since colors vary from monitors versus what is printed on paper versus our ceramic paints.

Process vs. Spot



Vectorized Spot color



Enlarged to show details

The above image was printed using Spot color process printing. In order to achieve the colors needed in the individual file we had to pick solid PMS colors as the files below show. Our inks are Ceramic based and do not mix or blend to create other colors as Process inks do. We also need to print White whereas printing process on White paper essentially makes the White a “free” color, this is one advantage printing on glass that we do not have.

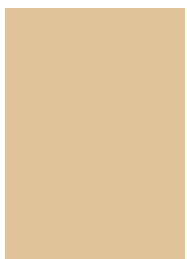

PMS
466



PMS
186

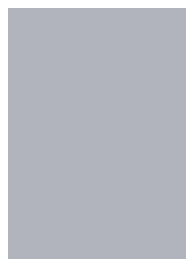

PMS
429



PMS
293



BLACK

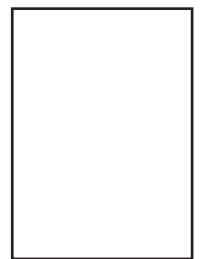

WHITE

Process vs. Spot



Original 4 color process

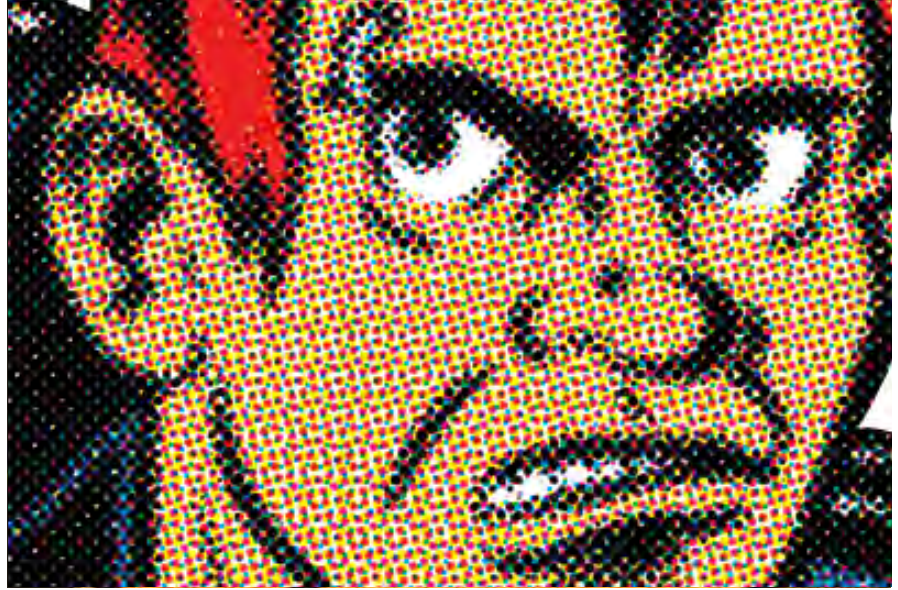

Enlarged to show "dots"

The above image was printed using 4 color process printing. If you take a look at the image below it shows how process inks are used to combine basic colors to create new colors. If you take a closer look at the enlarged areas you can see where the colors have overlapped and created new colors. We **Do NOT** print four color process.

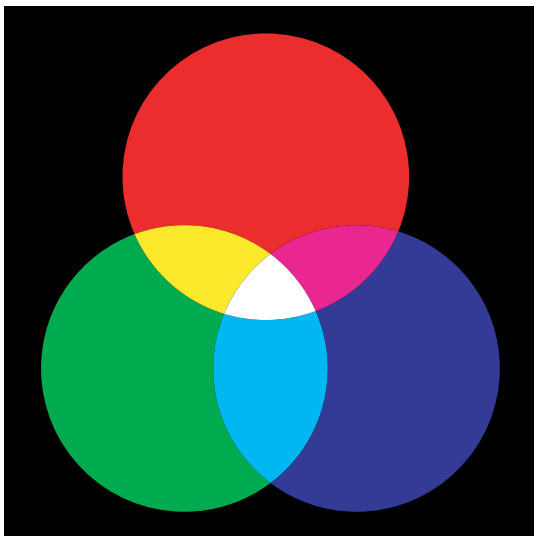

Red, Green, Blue

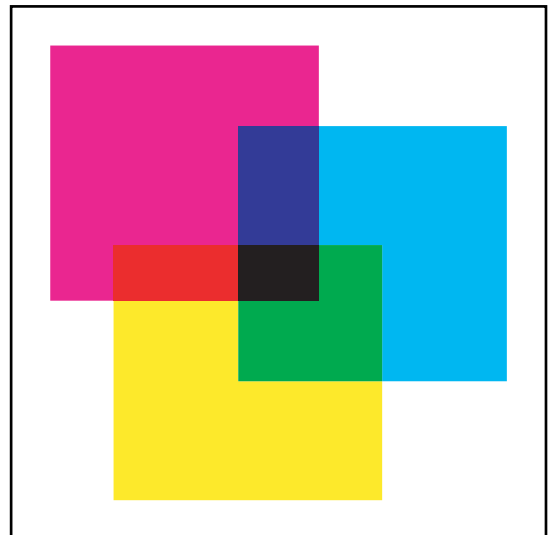

Cyan, Magenta, Yellow

Printing

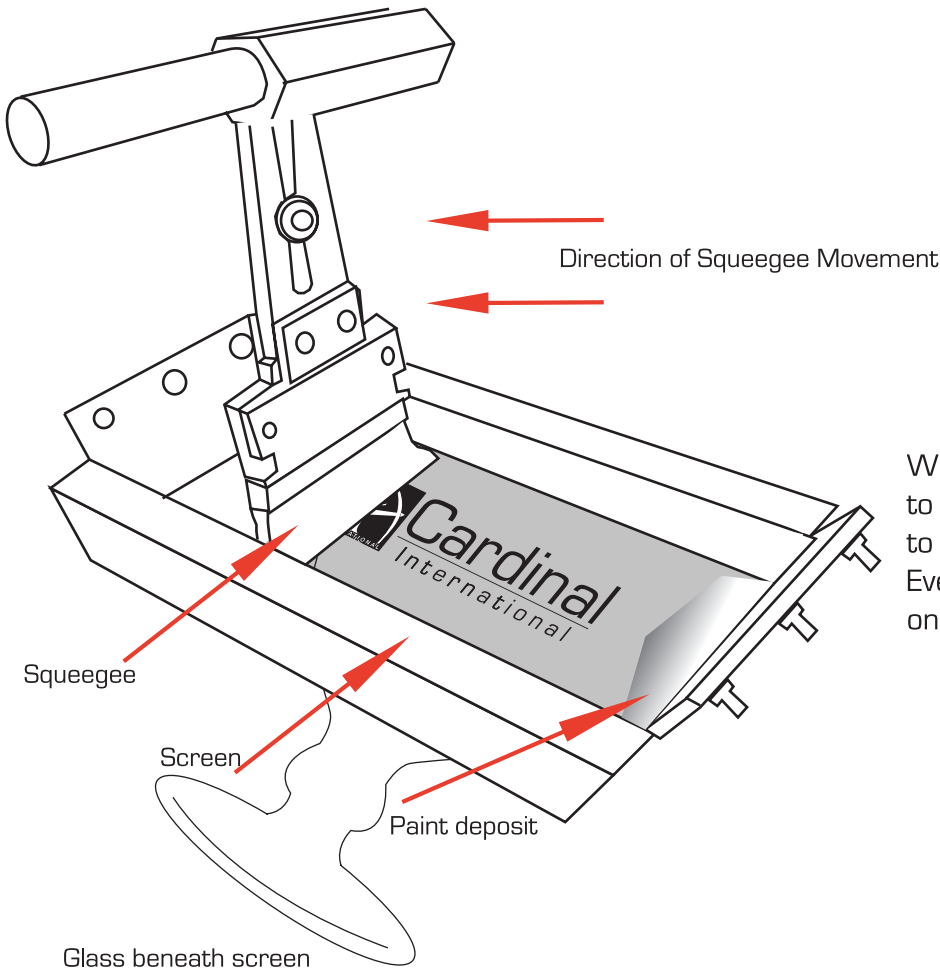

We use steel screens that do not conform to the curves of the glass. Thus we are limited to printing on only the flattest area of the glass. Every glass will have different print areas based on their shapes.



Finished product

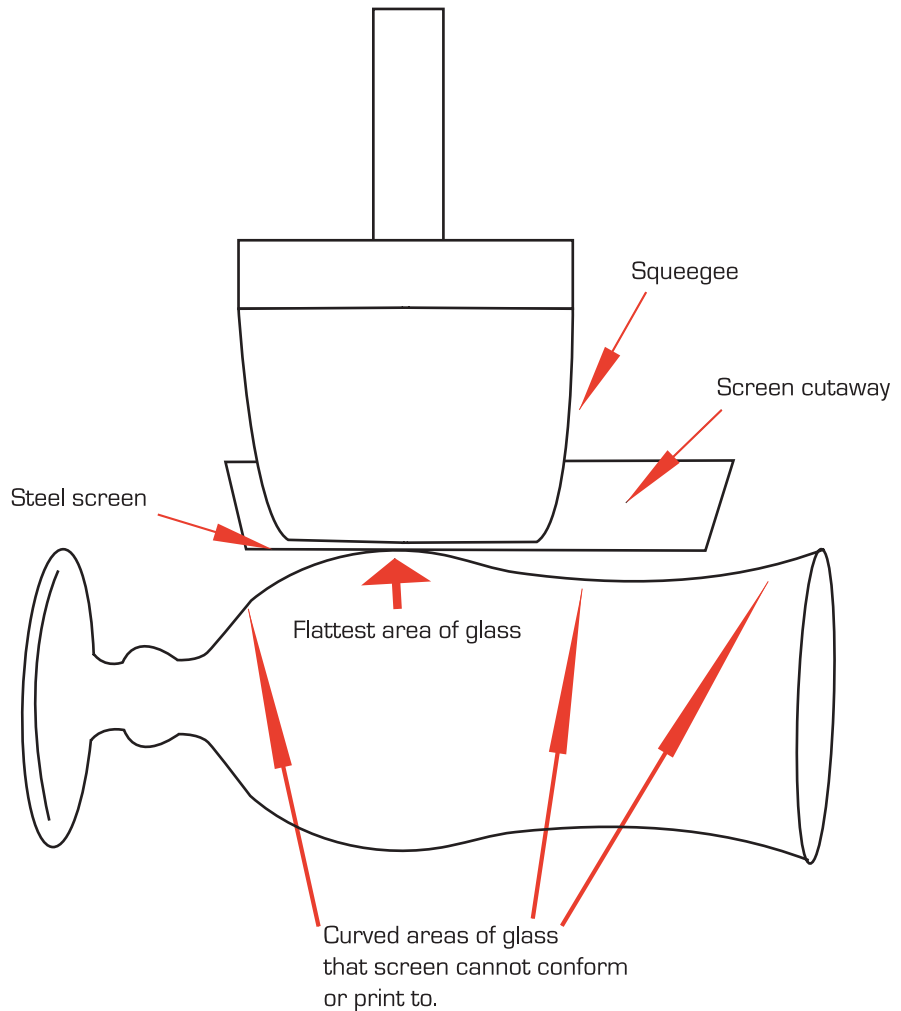

Custom Glassware Contact Information

Mike Nelson

Plant Production Supervisor

Tel: 973.628.0900 ext - 6164

Fax: 973.686.2122

E-Mail: mike.NELSON@arc-intl.com

Alex Nagy

Decorated Facility Production Coordinator

Tel: 973.628.0900 ext - 6351

Fax: 973.686.2122

E-Mail: alexander.NAGY@arc-intl.com

Hector Raso

Art Director, North America

Tel: 973.628.0900 ext - 6352

Fax: 973.686.2122

E-Mail: hector.RASO@arc-intl.com

Michael Pecorini

Assistant Art Director, North America

Tel: 973.628.0900 ext - 6353

Fax: 973.686.2122

E-Mail: michael.PECORINI@arc-intl.com

Steven Mazzaro

Beverage Account Sales Associate

Tel: 973.628.0900 ext - 6127

Fax: 973.686.2122

E-Mail: steven.MAZZARO@arc-intl.com

When sending artwork e-mail is the preferred medium. Since e-mail is instant this will result with the fastest turnaround time. For files that are too large to e-mail (hi-res tiff's especially) please contact Michael Pecorini for information on sending files via our FTP. When mailing us art ("Snail-Mail") expect a delay on art approval and proof/sample time due to shipping time. Place make all packages at attention to Hector Raso or Michael Pecorini to:



30 Corporate Drive
Wayne, NJ 07470

Our full line of glassware can be found at <http://www.cardinalglass.com> or to request a catalog please contact our customer service department at 973.628.0900.