

## Perfect•Serv II



## Retherm and Deliver Meals ... Service with Style!

Introducing the new generation of bulk retherm meal service. A Retherm oven, refrigerator, and serving counter all in one attractive mobile unit.

The Perfect•Serv II is today's answer to foodservice excellence in healthcare, with stylish design and functional applications. With oven and refrigerated compartments, the Perfect•Serv II will hold chilled food at 35°F (2°C) and then rethermalize manually or pre-programmed on a 7 day timer.

After retherm, transfer hot foods to the hot top and maintain optimal serving temperatures throughout the meal service. Enhance the customer dining experience by serving quality foods on location and direct to the plate, while maintaining hot and cold food temperatures.

Perfect•Serv II bulk retherm carts are HACCP compliant and feature 6" heavy-duty casters, full protector guards with halogen heat lamps and wrap-around bumpers. Monitor food quality with the on-board temperature probe and data-logging system for maximum safety and compliance.

Perfect•Serv II Features Include:

- User-friendly retherm programming
- No pre-heat required
- Fully automatic options
- Refrigerate and rethermalize in the same compartment
- HACCP compliant Data Logging System
- Conforms to HACCP food safety regulations and recommendations
- Hot compartments boost function
- Uses only 120 volt power to hold and serve anywhere
- Serves up to 40 meals depending on menu



The Perfect•Serv Cart can be easily transported from the kitchen to the serving area or each location can be serviced using the Transport Dolly and 8 level cassette system

Consolidate all serving elements for the Perfect•Serv system on one efficient support cart from Dinex. The support cart holds trays, china, napkins, utensils and beverage dispensers along with all necessary serving supplies.

## Perfect•Serv II Mobile Bulk Retherm Carts and Options

<u>Item #</u>	<u>Description</u>	<u>UPC</u>	<u>List Price</u>
DXPSIIGG	Perfect•Serv II – Double Oven (Available August 2010)	753806461062	\$31,022.00
DXPSIIGR	Perfect•Serv II – One oven, one refrigerator (8 pan oven/8 pan refrigerator)	753806461079	\$30,302.00
DXPSIICR	Perfect•Serv II – One oven/refrigerator, one refrigerator (8 pan oven / refrigerator combo)	753806461048	\$33,034.00

### Options

DXPSII8C	Cassette 8 level (for extra quantities)	753806461291	\$658.00
DXPSIIGS	Grid shelves (for extra quantities)	753806461307	\$72.00
DXPSIIES	End shelf	753806461222	\$207.00
DXPSIITB	Fold up tow bar with hitch assembly	753806461260	\$1,600.00
DXPSIITP	Integral food tem probe with holster- detachable	753806461253	\$658.00
DXPSIITS	Fold down tray slide	753806461215	\$880.00
DXPSIIR4	4 <sup>th</sup> Rail	753806461390	\$264.00
DXPSIITD	Transfer Dolly	753806461444	\$3,388.00
DXPSIITDC	Transfer Dolly Cover	753806461451	\$474.00
DXPSIISRC	Single Thermal Cover (for one Stack)	753806461970	\$420.00
DXPSIITDLD	Locking device; retro fit with transfer dolly	753806461932	\$172.00
DXPSIICREAD	Card Reader	753806461321	\$426.00
DXPSIISCB	SmartCard – Blue, Data Transfer	753806461925	\$52.00
DXPSIISCG	SmartCard – Green, Programming	75380461949	\$52.00
DXPSIISOFT	Software program (per cart)	75380461338	\$1,650.00

## Perfect•Serv II Support Cart and Options

<u>Item #</u>	<u>Description</u>	<u>UPC</u>	<u>List Price</u>
DXPSSCII	Support Cart (Includes overhead shelf, front enclosure panel, 3 pair of fixed slides, 2 pair of roller slides, Stainless Steel front and end panels)	753806461406	\$9,746.00

### Options

DXPSSCIIEO	120V Electrical outlet	753806461413	\$100.00
DXPSSCIIFS	Fixed Interior Slide (adjustable height); Set of two	753806461529	\$80.00
DXPSSCIIFTS	Folding Tray Slide	753806461420	\$1,188.00
DXPSSCIIRS	Interior Adjustable Roller Slide	753806461536	\$432.00

For additional product information on Perfect•Serv II, please see the attached specification sheets.

## PERFECT•SERV™ II



### Application

Rethermalizes bulk chilled/frozen food to table ready temperatures in approximately one hour (no-preheat required). Chillotherm allows you to hold chilled bulk food for an extended time and then rethermalizes the food automatically using state of the art programable controller hardware and software.

### Construction

Fully welded cabinet construction to meet institutional requirements. Food areas constructed primarily of 16 and 18 gauge, 304 Stainless Steel. Exterior panels are formed from a light weight and extremely durable industrial grade ABS material. Design emphasis is based on function, ergonomics, clean ability, and dependability.

### Standard Features

User friendly programming implementing management security and ease through the use of a reprogrammable "Smart Card". Microcircuit control technology. Programming parameters provide for automatic start, stop, program retention, power interruption, maintenance notification, upgrading, and communication. Plexiglas protector guard with halogen

lamps, two individually controlled structurally supported stainless steel hot top surfaces, compliant dual voltage capability. Hot tops and lamps controlled manually or automatically. Six, 6-inch caster configuration, (4) swivels located at corners, (2) rigid located in center of base, allow zero turning radius. Easi-Roll internal cassettes suitable for simple placement on transfer dolly (optional), easily accessible interior control components, smooth coved food cavities to provide easy cleaning.

Convection heat generator couples with high efficiency fan and element utilizing thermal profiling technology, providing equally distributed heating throughout the compartment.

Rethermalizes with stainless steel, disposable aluminum pans or china.

### Additional Options

- HACCP compliant data logging system with Food Probe
- End service shelf (up to 2)
- Tubular stainless steel trayslide with area for cutlery/condiment dispensers
- 4<sup>th</sup> Top Rail

### Item Numbers

#### Perfect•Serv II Cart

- DXPSIICR
- DXPSIIGR
- DXPSIIGG

- Additional Easi-Roll internal cassettes for transfer dolly
- Cassette wire grid shelves
- Transfer dolly
- Color matching temperature retention cover for transfer dolly

### Electrical Specification

- 120v / 208v, 3-phase, 30 AMP for DXPSIICR & DXPSIIGR models. Maximum power consumption on any leg is 24 AMPS.
- 120v / 208v, 3-phase, 60 AMP Pin & Sleeve plug for PSIIGG model. Maximum power consumption on any leg is 27 AMPS.

### Warranty

One year parts and labor.



TOP O' THE TABLE

420 Westdale Avenue  
Westerville, OH 43082

T 614.899.9500

800.492.7400

F 614.899.9797

I www.topothetable.com

# PERFECT•SERV™ II

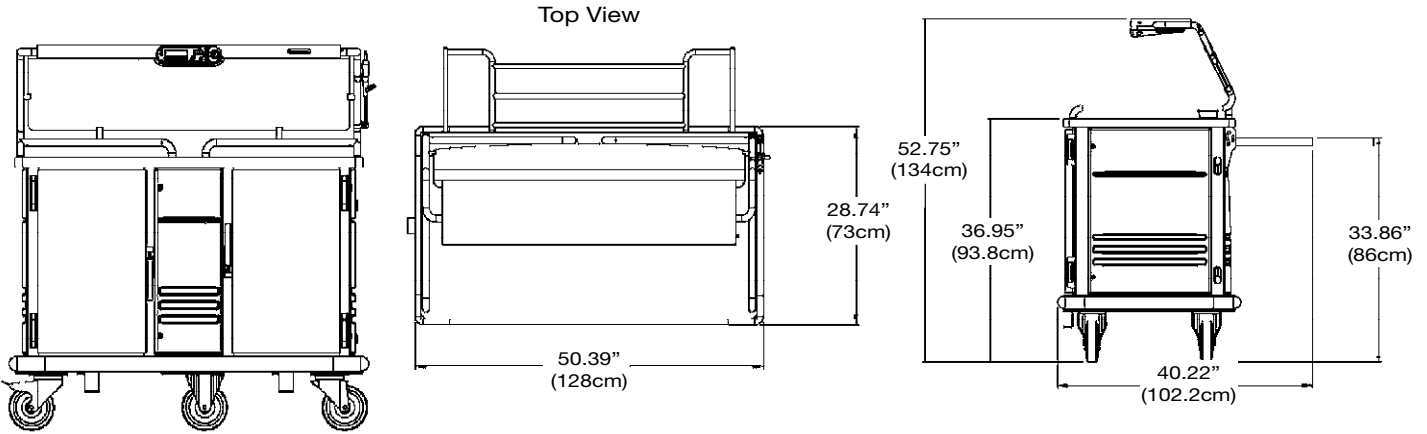

## Perfect•Serv™ II Specifications

ITEM NUMBER	MODEL NUMBER	FEATURES	NOISE RATING (DECIBELS)	EMPTY OPERATING WEIGHT	SHIP WEIGHT
DXPSIICR	PSIICR	One (8 full size or 16 1/2 size) Pan Chillotherm Combined Oven/Fridge and One (8 full size or 16 1/2 size) Pan Refrigerated Compartment	55	352 lb. (160kg)	485 lb. (220kg)
DXPSIIGR	PSIIGR	One (8 full size or 16 1/2 size) Pan Convection Oven and One (8 full size or 16 1/2 size) Pan Refrigerated Compartment	55	352 lb. (160kg)	485 lb. (220kg)
DXPSIIGG	PSIIGG	Two (8 full size or 16 1/2 size) Pan Rethermalization Ovens (No Refrigeration)	55	325 lb. (147kg)	456 lb. (207kg)



## PLUG CONFIGURATIONS

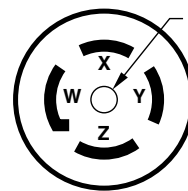

For PSIICR & PSIIGR models - NEMA L21-30  
120v / 208v, 3-phase, 30 AMP

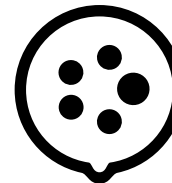

For PSIIGG model - 120v / 208v 3-phase, 60 AMP pin & sleeve plug

Note: Pan references are for full size retherm steam pans, 12" X 20" X 2.5" Deep

- Easi-Roll cassettes for 8 pan areas are standard on all units and are mounted on stainless steel wheels for roll in/roll out onto transfer dolly.
- Digital temperature display is in Fahrenheit or Celsius.
- The 120 volt adapter provides power to the controller, hot tops, lamps, and refrigeration if applicable.
- ½ Pans recommended for flexibility.

## PERFECT•SERV™ II & HOLD-N-SERV SUPPORT CART



### Item Number

DXPSSCII

### Application

The Support Cart is the auxiliary cart needed to complement the bulk rethermalization and holding carts. It is specifically designed to compliment these products to provide the total meal service to a patient or student at the serving area (pantry, patient floor, dining or multi-purpose room).

### Construction

Fully welded stainless steel construction to meet institutional requirements. Solid formed tray slides and drawer type slides supplied with each unit. Slides are sized for use on either side of cart and have a 1 inch incremental adjustment. Compartments and slides sized to accommodate multiple size trays, pans, and drying racks. Tubular top rail assembly is mechanically fastened for easy removal or replacement in field. Upper and lower surfaces are secured with a lengthwise formed cross support. Stainless Steel front and end enclosures with laminate colors Indigo Blue or Deepstar Slate. Please verify color selection when ordering. Over shelf is designed to accommodate up to (3) 1/3 size pans.

### Standard Features

- Full stainless construction
- Overhead Shelf with 3 inch adjustable height
- Divider bars for overhead shelf to support up to (3) 1/3 size pans (provided by customer)
- (3) sets of universal solid adjustable shelving/slides
- (2) sets of adjustable drawer slide shelves
- 1 inch incremental adjustment on shelves
- Shelves/Slides interchangeable from side to side
- Drawer slide shelves and over shelf held firmly in place with release pins
- (3) sided top rail system
- Full perimeter bumper
- Push handle
- 6 inch casters. 2 Rigid, 2 swivel with brakes on handle end of cart
- Heavy substructure to provide rigidity on working surface
- Drain hole with secured plug in each section
- Choice of laminate colors

### Tasks of Beverage/Nourishment Cart

- Compliments any patient tray delivery system
- Mobile Catering
- Coffee Break
- Room Service Program

### Benefits

- Responds to individual special needs example: extra cup of coffee
- Less interruption to nursing staff
- Less informal inventory on floors
- Reduces beverage cost with bulk carbonated beverage instead of cans
- Reduces food waste with patients
- Enhances recycling without losing portion control
- Patients/Visitors/Administration – happier with better service – direct impact on patient

### Options

- 120 VAC - 15 Amp Electrical Outlet
- Solid Folding Tray Slide
- Additional Solid Tray Slides
- Additional drawer shelf assembly
- 6<sup>th</sup> caster package
- Drop down end shelf

### Warranty

One year parts and labor.



TOP O' THE TABLE

420 Westdale Avenue  
Westerville, OH 43082

T 614.899.9500

800.492.7400

F 614.899.9797

I www.topothetable.com



# PERFECT•SERV™ II & HOLD-N-SERV SUPPORT CART

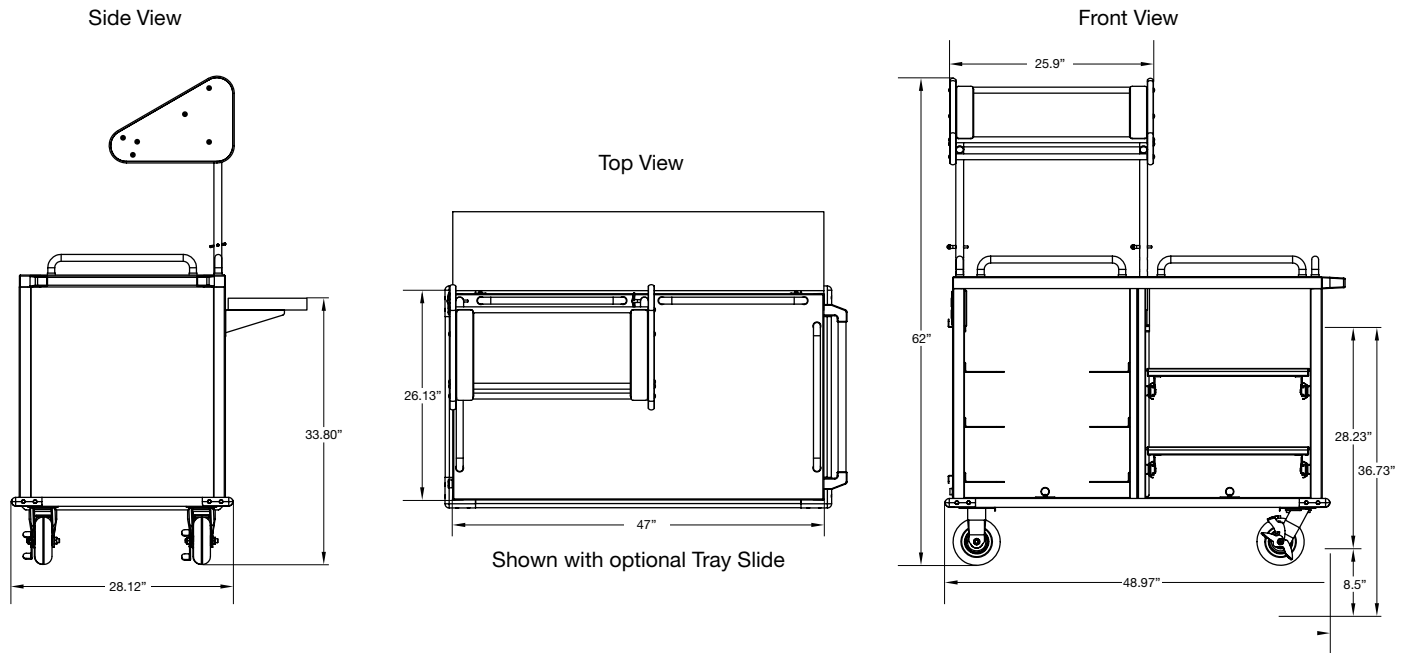

## Dimensions

ITEM NUMBER	MODEL NUMBER	HEIGHT (Including Over Shelf)	HEIGHT TO WORK SURFACE	LENGTH	WIDTH (Not Including Optional Tray Slide)	SHIP WEIGHT
DXPSSCII	PSSCII	62" (157 cm)	36.73" (93.3 cm)	48.97" (124.4 cm)	26.13" (66.4 cm)	480 lb. (218kg)

ITEM NUMBER	MODEL NUMBER	DESCRIPTION	STANDARD / OPTIONAL
DXPSSCII	PSSCII	Perfect Serv II & Hold-N-Serv Support Cart Base Unit	Cart
-	-	Overhead Shelf	Standard
-	-	Front Enclosure Panel	Standard
-	-	(3) Pair of DXPSSCIIFS Fixed Slides	Standard
-	-	(2) Pair of DXPSSCIIRS Roller Slides	Standard
DXPSSCIIEO	PSSCIIEO	Outlet: DXPSSCII 120V Electrical	Optional
DXPSSCIIFTS	PSSCIIFTS	Slide: DXPSSCII Folding Tray	Optional
DXPSSCIILP001	PSSCIILP001	Laminate: Indigo Blue DXPSSCII Front and End Panel	Standard Selection
DXPSSCIILP002	PSSCIILP002	Laminate: Deepstar Slate DXPSSCII Front and End Panel	Standard Selection
DXPSSCIIFS	PSSCIIFS	Slide: Fixed Interior Adjustable (set of 2)	Optional
DXPSSCIIRS	PSSCIIRS	Slide: Roller Interior Adjustable	Optional
DXPSS6CAST	PSSII6CAST	6 Caster Package	Optional
DXPSSCIIES	PSSCIIES	Drop Down End Shelf	Optional

## PERFECT•SERV™ II & HOLD-N-SERV TRANSFER DOLLY & CASSETTE SYSTEM



### Item Numbers

#### Transfer Dolly

- DXPSIITD - Transfer Dolly

#### Transfer Dolly Options

- DXPSIISRC - Insulated Rack Cover
- DXPSIITDC - Transfer Dolly Cover
- DXPSIITDLD - Locking Device

### Application

Support Perfect•Serv II and Hold-N-Serv product lines by providing a platform for pre-assembly and staging of product. Allows for immediate transfer at time of need. Provides lighter transport in lieu of using the Retherm or Holding Cart.

### Construction

All food areas and substructure are constructed of, 304 Stainless Steel. All joints are fully welded.

### Standard Features

(4) Swivel 4 inch casters allow easy movement. One caster with brake feature to prevent movement, when necessary. Locking feature to secure Shuttle to the Retherm or Holding Cart during transfer of cassette from Shuttle to Cart. Foot operated locking mechanism to secure the Cassettes during transport. Push handle height is designed for optimum pushing and control.

### Additional Supporting Components

- (8) Level Cassette – fabricated from heavy gauge wire. Contains Stainless Steel rollers on lower supports to allow easy movement from Transfer Dolly to Cart and vice versa. Light yet strong.
- Grid Shelf – fabricated from Stainless Steel wire. Designed to be self supporting when installed in the Cassette. Formed feature reduces the risk of disengaging the Shelf from the Cassette accidentally
- Transfer Dolly Cover – fabricated from heavy vinyl. Cassette transfer side contains flap that will allow removal of cassettes without full removal of cover.

### Warranty

One year parts and labor.



TOP O' THE TABLE

420 Westdale Avenue  
Westerville, OH 43082

T 614.899.9500  
800.492.7400

F 614.899.9797

I [www.topothetable.com](http://www.topothetable.com)

# PERFECT•SERV™ II TRANSFER DOLLY & CASSETTE SYSTEM

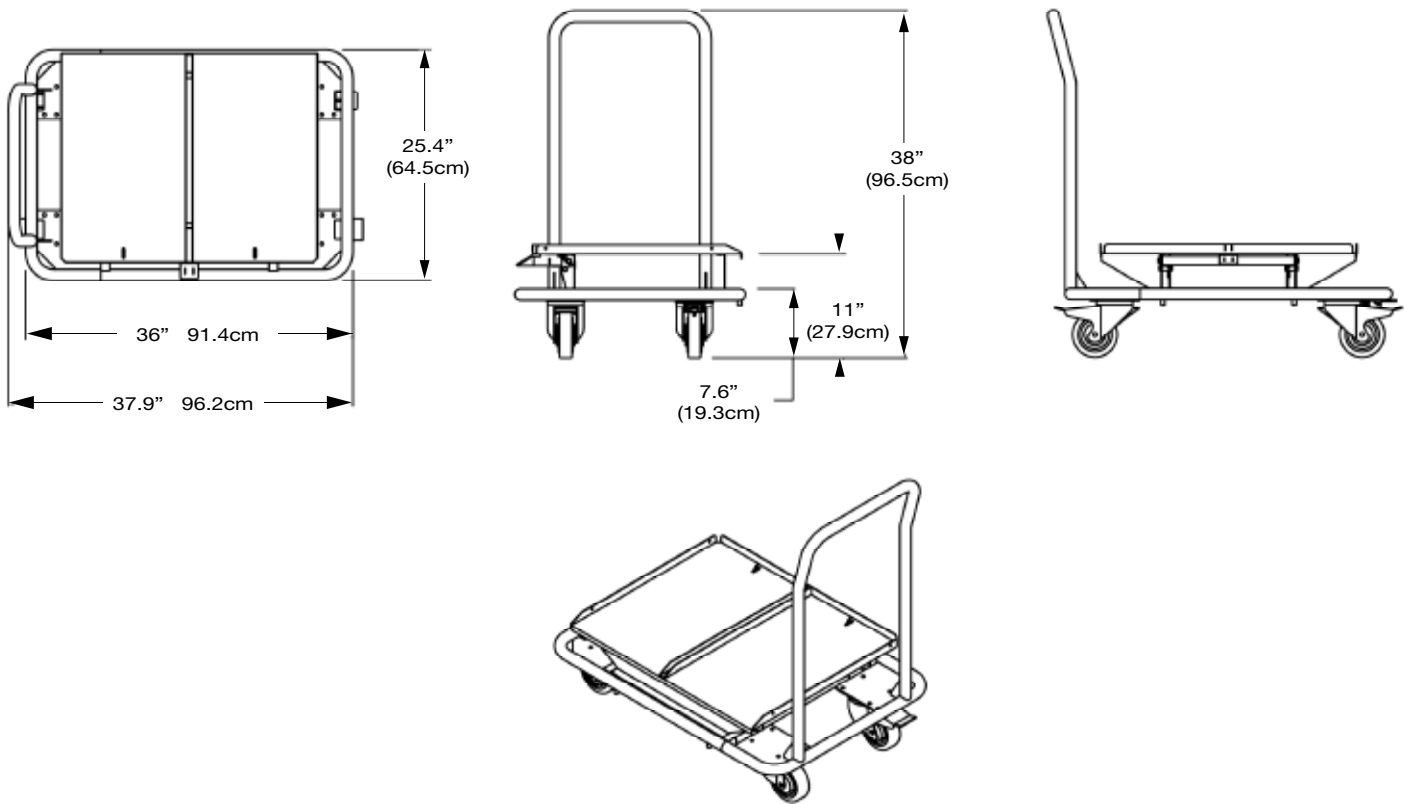

## Items and Dimensions

ITEM NUMBER	MODEL NUMBER	LENGTH	DEPTH	HEIGHT	SHIP WEIGHT	SHIP CUBE
DXPSIITD	PSIITD	25.4" (64.5cm)	37.9" (96.2cm)	38" (96.5cm)		

## Options

ITEM NUMBER	MODEL NUMBER	DESCRIPTION
DXPSIITDC	PSIITDC	Vinyl Cover for Transfer Dolly
DXPSIISRC	PSIISRC	Insulated Rack Cover for Hot Side of Dolly
DXPSIITDLD	PSIITDLD	Locking Device Retro Fit with Transfer Dolly